

ERGOTIG 24W

CE EN60974-7



CODE	↔		↕	TSK 50-1/4G
SY1410-00	4 m	12.5'	sintig	
SY1810-00	8 m	25'	sintig	
SZ1410-00	4 m	12.5'	sintig flex	
SZ1810-00	8 m	25'	sintig flex	

TECHNICAL DATA	
ERGOTIG 24W	
	0,45 kg 0.99 lb
	113
V PEAK	Argon
	Argon
	0,5 ÷ 2,4 mm .020" ÷ 3/32"
X 100%	180A DC - 120A AC
	4 bar
	1.5 l/min

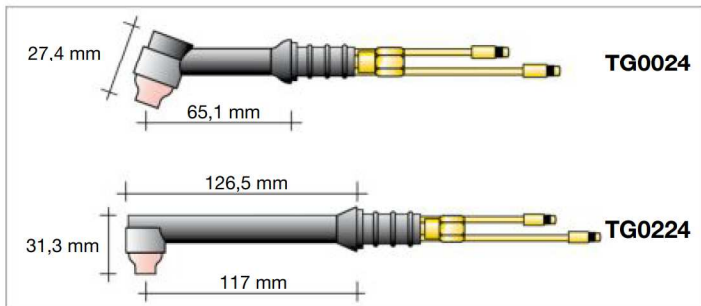

	CODE			
4	TQ0004		insulator	10
5	TG0024		tig 24W torch head - 65,1 mm	1
6	TG0224		tig 24W flex torch head - 117 mm	1
8	TT0181		kit Ergotig single	1
9	TT0182		kit Ergotig dual	1
10	BW0304		reduction	1
10	BW0311		cable joint	1
10	EA0329		screw	50
10	TP0090		Ergotig handle	1
11	TH0147		cable assembly - 4 m / 12.5'	1
11	TH0148		cable assembly - 8 m / 25'	1
12	TH0086		power cable - 4 m / 12.5'	1
12	TH0087		power cable - 8 m / 25'	1
15	CX0080		TSK 50 - quick plug	1



WEAR PARTS NOT INCLUDED

Starter kits page 360
Wear parts page 364

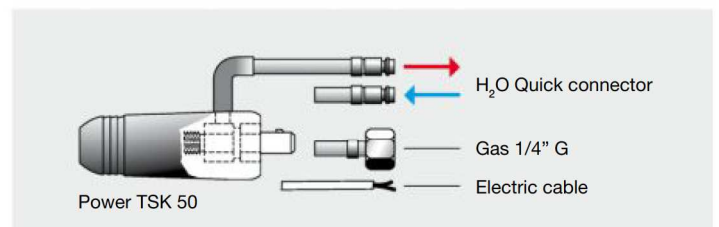

TIG TORCH HEADS



MANUAL

CODE			
TF0009		TIG 9	1
TF0010		TIG 9 FLEX	1
TF0222		TIG 9 FLEX 100 mm	1
TF0017		TIG 17	1
TF0022		TIG 17 FLEX	1
TF0024		TIG 24	1
TF0224		TIG 24 FLEX	1
TF0026		TIG 26	1
TF0027		TIG 26 FLEX	1

VALVE

CODE			
TF0109		TIG 9 V	1
TF0110		TIG 9 V FLEX	1
TF0117		TIG 17 V	1
TF0118		TIG 17 V FLEX	1
TF0126		TIG 26 V	1
TF0127		TIG 26 V FLEX	1

AUTOMATIC

CODE			
TF1000		AUTOTIG 9	1
TF1001		AUTOTIG 26	1



FLEXLOCK

CODE			
TF0072		FLEXLOCK 17 - 18	1
TF0071		FLEXLOCK 9 - 20	1
TF0070		FLEXLOCK 9 - 17	1
BW0535		fixing screw FLEXLOCK 9 - 17 - 18 - 20	1

MANUAL

CODE			
TG0018		TIG 18	1
TG0118		TIG 18 FLEX	1
TG0913		TIG 18 HC	1
TG0914		TIG 18 HC FLEX	1
TG0020		TIG 20	1
TG0220		TIG 20 FLEX	1
TG0223		TIG 20 FLEX 125 mm	1
TG0912		TIG 20 HC	1
TG0911		TIG 20 HC FLEX	1
TG0024		TIG 24W	1
TG0224		TIG 24W FLEX	1
TG0025		TIG 25	1
TG0917		SUPER 50	1

AUTOMATIC

CODE			
TG1001		AUTOTIG 18	1
TG1000		AUTOTIG 20	1



FLEXLOCK

CODE			
TF0072		FLEXLOCK 17 - 18	1
TF0071		FLEXLOCK 9 - 20	1
TG0070		FLEXLOCK 18 - 20	1
BW0535		fixing screw FLEXLOCK 9 - 17 - 18 - 20	1

TUNGSTEN ELECTRODES

CE UNI EN ISO 6848-2004



CODE		\varnothing	\longleftrightarrow	
TR0001-10		1 mm	150 mm	1
TR0001-16		1,6 mm	150 mm	1
TR0001-20	WP	2 mm	150 mm	1
TR0001-24		2,4 mm	150 mm	1
TR0001-32		3,2 mm	150 mm	1
TR0001-40		4 mm	150 mm	1
TR0001-48		4,8 mm	150 mm	1
TR0002-10	WP	1 mm	175 mm	1
TR0002-16		1,6 mm	175 mm	1
TR0002-20		2 mm	175 mm	1
TR0002-24		2,4 mm	175 mm	1
TR0002-32		3,2 mm	175 mm	1
TR0002-40		4 mm	175 mm	1
TR0002-48		4,8 mm	175 mm	1
TR0002-64		6,4 mm	175 mm	1
TR0007-10	WC20	1 mm	150 mm	1
TR0007-16		1,6 mm	150 mm	1
TR0007-20		2 mm	150 mm	1
TR0007-24		2,4 mm	150 mm	1
TR0007-32		3,2 mm	150 mm	1
TR0007-40		4 mm	150 mm	1
TR0007-48		4,8 mm	150 mm	1
TR0008-10	WC20	1 mm	175 mm	1
TR0008-16		1,6 mm	175 mm	1
TR0008-20		2 mm	175 mm	1
TR0008-24		2,4 mm	175 mm	1
TR0008-32		3,2 mm	175 mm	1
TR0008-40		4 mm	175 mm	1
TR0008-48		4,8 mm	175 mm	1
TR0011-10	WL10	1 mm	150 mm	1
TR0011-16		1,6 mm	150 mm	1
TR0011-20		2 mm	150 mm	1
TR0011-24		2,4 mm	150 mm	1
TR0011-32		3,2 mm	150 mm	1
TR0011-40		4 mm	150 mm	1
TR0011-48		4,8 mm	150 mm	1
TR0012-16	WL10	1,6 mm	175 mm	1
TR0012-24		2,4 mm	175 mm	1
TR0012-32		3,2 mm	175 mm	1

CODE		\varnothing	\longleftrightarrow	
TR0013-10	WL15	1 mm	150 mm	1
TR0013-16		1,6 mm	150 mm	1
TR0013-20		2 mm	150 mm	1
TR0013-24		2,4 mm	150 mm	1
TR0013-32		3,2 mm	150 mm	1
TR0013-40		4 mm	150 mm	1
TR0013-48		4,8 mm	150 mm	1
TR0014-10	WL15	1 mm	175 mm	1
TR0014-16		1,6 mm	175 mm	1
TR0014-20		2 mm	175 mm	1
TR0014-24		2,4 mm	175 mm	1
TR0014-32		3,2 mm	175 mm	1
TR0014-40		4 mm	175 mm	1
TR0014-48		4,8 mm	175 mm	1
TR0017-10	WL20	1 mm	150 mm	1
TR0017-16		1,6 mm	150 mm	1
TR0017-20		2 mm	150 mm	1
TR0017-24		2,4 mm	150 mm	1
TR0017-32		3,2 mm	150 mm	1
TR0017-40		4 mm	150 mm	1
TR0017-48		4,8 mm	150 mm	1
TR0018-10	WL20	1 mm	175 mm	1
TR0018-16		1,6 mm	175 mm	1
TR0018-20		2 mm	175 mm	1
TR0018-24		2,4 mm	175 mm	1
TR0018-32		3,2 mm	175 mm	1
TR0018-40		4 mm	175 mm	1
TR0021-10	WR2	1 mm	150 mm	1
TR0021-16		1,6 mm	150 mm	1
TR0021-20		2 mm	150 mm	1
TR0021-24		2,4 mm	150 mm	1
TR0021-32		3,2 mm	150 mm	1
TR0021-40		4 mm	150 mm	1
TR0021-48		4,8 mm	150 mm	1
TR0022-10	WR2	1 mm	175 mm	1
TR0022-16		1,6 mm	175 mm	1
TR0022-20		2 mm	175 mm	1
TR0022-24		2,4 mm	175 mm	1
TR0022-32		3,2 mm	175 mm	1
TR0022-40		4 mm	175 mm	1

WEAR PARTS KITS



STARTER KITS



9 - 20 - 20 HC - 25

CODE	Ø			
TT0101	1,6 mm	1/16"	WR2	1
TT0102	2,4 mm	3/32"	WR2	1

17 - 18 - 18 HC - 26

CODE	Ø			
TT0103	1,6 mm	1/16"	WR2	1
TT0104	2,4 mm	3/32"	WR2	1
TT0105	3,2 mm	1/8"	WR2	1

24 - 24W

CODE	Ø			
TT0203	1,6 mm	1/16"	WC20	1
TT0204	2,4 mm	3/32"	WC20	1

MASTER KITS



9 - 20 - 20 HC - 25

CODE	Ø		
TT0109	1,0 mm - 1,6 mm - 2,0 mm - 2,4 mm - 3,2 mm		1

17 - 18 - 18 HC - 26

CODE	Ø		
TT0110	1,6 mm - 2,0 mm - 2,4 mm - 3,2 mm - 4,0 mm		1

STARTER KITS



9 - 20 - 20 HC - 25

CODE	Ø			
TT0221	1,6 mm	1/16"		1
TT0222	2,4 mm	3/32"		1

17 - 18 - 18 HC - 26

CODE	Ø			
TT0223	1,6 mm	1/16"		1
TT0224	2,4 mm	3/32"		1

24 - 24W

CODE	Ø			
TT0226	1,6 mm	1/16"		1

STARTER KITS WITH BACK CAP



9 - 20 - 20 HC - 25

CODE	Ø			
TT0021	1,6 mm	1/16"	WC20	1
TT0022	2,4 mm	3/32"	WC20	1

17 - 18 - 18 HC - 26

CODE	Ø			
TT0023	1,6 mm	1/16"	WC20	1
TT0024	2,4 mm	3/32"	WC20	1
TT0025	3,2 mm	1/8"	WC20	1

SERIES 24 - 24W WEAR PARTS



1



2



3



4

STANDARD

	CODE		Gr	Ø		↔	REF	
1	TC0021		.165	4 mm	5/32"	16 mm	53N23	10
1	TC0022		4	6,4 mm	1/4"	16,5 mm	53N24	10
1	TC0023		5	8 mm	5/16"	15,6 mm	53N25	10
1	TC0024		6	9,8 mm	3/8"	15,6 mm	53N27	10
1	TC0027		4	6,4 mm	1/4"	29 mm	53N28	10
1	TC0028		6	9,8 mm	3/8"	29 mm	53N26	10
2	TE0004-05			0,5 mm	.020"	12 mm	53N17	10
2	TE0004-10			1,0 mm	.040"	12 mm	53N18	10
2	TE0004-16			1,6 mm	1/16"	12 mm	53N19	10
2	TE0004-24			2,4 mm	3/32"	12 mm	24CB332	10
3	TD0004-10			1,0 mm	.040"	14 mm	53N16	10
3	TD0004-16			1,6 mm	1/16"	14 mm	53N14	10
3	TD0004-24			2,4 mm	3/32"	14 mm	24C332	10
4	TQ0004						53N22	10

GAS LENS

	CODE		Gr	Ø		↔	REF	
1	TC0041		4	6,4 mm	1/4"	25,5 mm	53N58	10
1	TC0042		5	8 mm	5/16"	25,5 mm	53N59	10
1	TC0043		6	9,8 mm	3/8"	25,5 mm	53N60	10
1	TC0044		7	11,2 mm	7/16"	25,5 mm	53N61	10
1	TC0045		8	12,7 mm	1/2"	25,5 mm	53N61S	10
2	TE0005-05			0,5 mm	.020"	22 mm	45V41	10
2	TE0005-10			1,0 mm	.040"	22 mm	45V42	10
2	TE0005-16			1,6 mm	1/16"	22 mm	45V43	10
2	TE0005-20	Cu + CuZn		2,0 mm	5/64"	22 mm		10
2	TE0005-24			2,4 mm	3/32"	22 mm	45V44	10
3	TD0005-05			0,5 mm	.020"	23 mm	53N62	10
3	TD0005-10			1,0 mm	.040"	23 mm	53N63	10
3	TD0005-16			1,6 mm	1/16"	23 mm	53N64	10
3	TD0005-24			2,4 mm	3/32"	23 mm	24GLC332	10
4	TQ0024						53N66	10

TIG BLISTERED WEAR PARTS



CODE		DESCRIPTION	SIZE	PCS X	BOX X
BW0056P		tig cap 58 mm	17 - 18 - 26	3	10
BW0064P		back cap 53 mm	9 - 20	3	10
BW0065P		back cap 17,5 mm	9 - 20	3	10
BW0067P		back cap 22,5 mm	17 - 18 - 26	3	10
TC0003P		gr 5	17 - 18 - 26	6	10
TC0004P		gr 6	17 - 18 - 26	6	10
TC0005P		gr 7	17 - 18 - 26	6	10
TC0006P		gr 8	17 - 18 - 26	6	10
TC0007P		gr 10	17 - 18 - 26	6	10
TC0008P		gr 12	17 - 18 - 26	6	10
TC0012P		gr 4	9 - 20	6	10
TC0013P		gr 5	9 - 20	6	10
TC0014P		gr 6	9 - 20	6	10
TC0015P		gr 7	9 - 20	6	10
TC0016P		gr 8	9 - 20	6	10
TC0017P		gr 10	9 - 20	6	10
TD0001P16		Ø 1.6	17 - 18 - 26	4	10
TD0001P20		Ø 2.0	17 - 18 - 26	4	10
TD0001P24		Ø 2.4	17 - 18 - 26	4	10
TD0001P32		Ø 3.2	17 - 18 - 26	4	10
TD0001P40		Ø 4.0	17 - 18 - 26	4	10
TD0003P16		Ø 1.6	9 - 20	4	10
TD0003P20		Ø 2.0	9 - 20	4	10
TD0003P24		Ø 2.4	9 - 20	4	10
TD0003P32		Ø 3.2	9 - 20	4	10

CODE		DESCRIPTION	SIZE	PCS X	BOX X
TE0001P16		Ø 1.6	17 - 18 - 26	3	10
TE0001P20		Ø 2.0	17 - 18 - 26	3	10
TE0001P24		Ø 2.4	17 - 18 - 26	3	10
TE0001P32		Ø 3.2	17 - 18 - 26	3	10
TE0001P40		Ø 4.0	17 - 18 - 26	3	10
TE0003P16		Ø 1.6	9 - 20	3	10
TE0003P20		Ø 2.0	9 - 20	3	10
TE0003P24		Ø 2.4	9 - 20	3	10
TE0003P32		Ø 3.2	9 - 20	3	10
TQ0001P		insulator	9 - 20	3	10
TQ0002P		insulator	17 - 18 - 26	3	10

